

LOC	DIST	REVISIONS					
EY	25	P	LTR	DESCRIPTION	DATE	DWN	APVD
		A		REVISED PER EC 0B40-0264-03	26APR04	SW	LH

⚠ MATERIAL: 0.38 [.015] THICK 70-30 BRASS Rb 50-65.

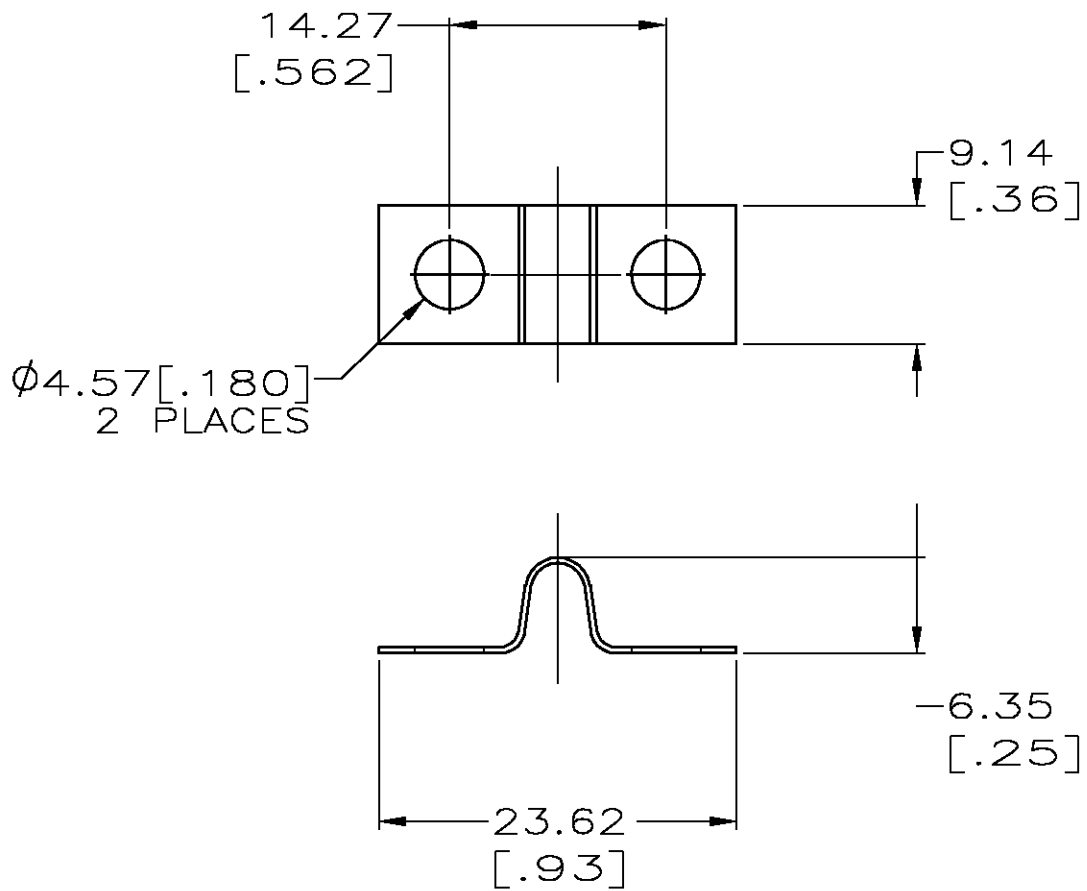

OBSOLETE	AS SHOWN	100 PER PACKAGE	604591-2
	NICKLE PLATE	BULK	604591-1
	FINISH	PACKAGING	PART NO.

RELEASED FOR PUBLICATION

ALL RIGHTS RESERVED.

BY TYCO ELECTRONICS CORPORATION.

THIS DRAWING IS UNPUBLISHED.

© COPYRIGHT

DIMENSIONS: mm [INCHES]	DWN	G. GARRETT	03FEB97	MATERIAL	⚠ -	FINISH	-
	CHK	G. GARRETT	03FEB97	Tyco Electronics Corporation Harrisburg, Pa 17105-3608			
TOLERANCES UNLESS OTHERWISE SPECIFIED:	APVD	E. HRYN	03FEB97				
0 PLC ± -	PRODUCT SPEC	-					
1 PLC ± -	APPLICATION SPEC						
2 PLC ± 0.51 [.02]	WEIGHT	-					
3 PLC ± 0.13 [.005]		SIZE	A4	CAGE CODE	00779	DRAWING NO	©-604591
4 PLC ± -		CUSTOMER DRAWING			SCALE	2:1	SHEET 1 OF 1
ANGLES ± -					RESTRICTED TO	-	
					REV	A	